

A very simple, effective CW Transmitter

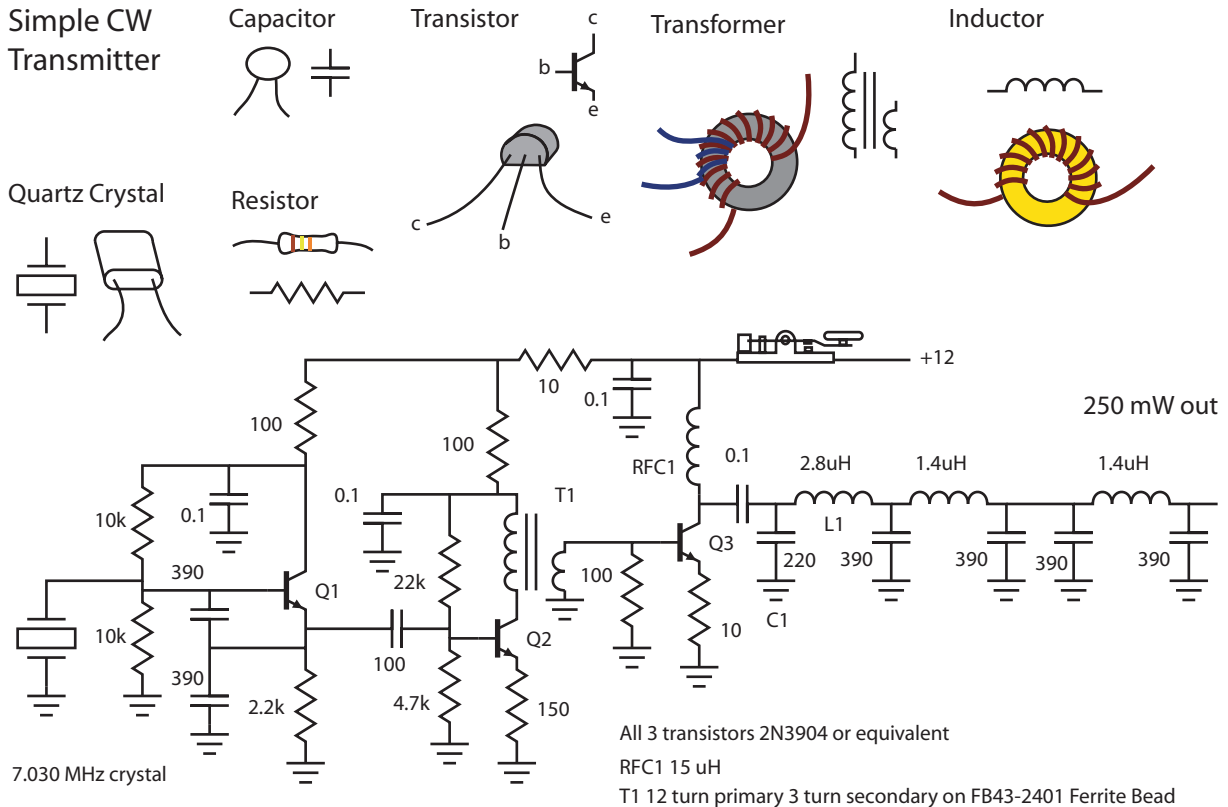

Notes: To optimize for 9v DC power, experiment with smaller values of emitter resistor on Q2, an extra turn on the secondary of T1, and use the Smith Chart to optimize the values of L1 and C1 for a lower impedance load presented to the collector of Q3. For more power output, Q3 may be paralleled 2N3904 devices or a different transistor type. Increasing the power output will require more drive from Q2

Several hundred of these simple transmitters have evolved since 2005 by RF Design students at Portland State University. Testing is done in class using a #47 light bulb load and a clip lead antenna to radiate enough signal to pick up in a nearby receiver. The original design by Wes Hayward appears as figure 1.34 in EMRFD, but students are encouraged/required to modify the design to meet different criteria.

Figure 1