

DDSV4 VFO Owner's Guide

The DDSV4 VFO is a new oscillator based on the Analog Devices AD9859 DDS numerical oscillator and an Atmel ATMEGA16 microcontroller.

Specifications

Power Req.	Backlight off = 6 to 7VDC, 150mA Backlight on = 6 to 7VDC, 240mA		Drift	30 – 40 Hz @ 10MHz for 5 min. warm-up, nil afterwards
Output Freq.	0 – 52 MHz		Clock Reference Freq.	25 MHz, multiplied X14 internally to 350MHz by the DDS
Output Power	800 mV into 50 Ohms		Size	1" X 2" (DDS Board) 1.5" X 3" (Display).
Harmonics	Down 45dB or more		Construction	Surface Mount
Freq. Control	Rotary Encoder – 100Hz Step default		Additional Controls	Band, Fast Step (3kHz default)

Features

User selectable modes – Ham, SWL, Sig Gen or Audio Oscillator. Ham band mode is the default.
 User selectable IF shift (offset) frequency. No IF shift is the default.
 Above Offset can be high or low side injection.
 User selectable step size.
 100Hz and 3kHz fast step is the default for Ham band mode. ←
 Outputs to automatically connect RF filters
 SMA RF output connector
 2X16 Backlit display standard. Backlight can be disabled to reduce current.
 Display provides information on frequency, mode, step size and offset frequency.
 Modular platform – user can change display, pushbuttons or encoder.

DEFAULTS:				
	Ham	SWL	SigGen	Audio
Step	100	1000	500	100
Fast Step	3k	5k	1k	

Operation

When power is applied to the unit, the Atmel microcontroller sends commands to the DDS chip to set initial registers and start oscillation at 1.8 MHz. After that sequence, the micro looks for a signal from the "Fast Step" pushbutton and the rotary encoder. If nothing is seen there, then it looks for an actuation of the Band pushbutton. If no input is found, it returns to look for a rotary encoder input. Once the unit is turned off and back on the process begins at 1.8 MHz again. The "Band" pushbutton is provided to jump between bands. In Ham mode the settings are 1.8, 3.5, 7.0, 10.0, 14.0, 21.0, 25.0, 28.0 and 50.0MHz.

Built onboard is a buffer stage to beef up the output enough to drive passive mixers. This is followed by a high-cut (low pass) "T" filter. This reduces the output by-products of the oscillator.

The microcontroller/DDS board rides piggy-back on a display module. The display provides a continuous update of frequency.

Hook-up

Hook up is very easy. The unit will start to oscillate with just the application of power and ground. The complete hookup is shown on the next page. A small board is also provided with the unit. It combines the functions of two pushbuttons and a rotary encoder. One pushbutton is to step through the bands and the other is for Fast Step. This design is modular so that user can reconfigure the pieces later to suit their own use.

1. The DDS board is plugged into a display – this can be changed later to a different type – most have the same pinout.
2. A different rotary encoder can be used – I have shown the pinout on the next page.

Calibration

Each unit is calibrated before shipment. This is done after a 10 minute warm-up, with input voltage set at 6.5V. The output frequency is adjusted to be within 10Hz within the indicated frequency at 10MHz. Note that changes to the input voltage can slightly affect the output frequency.

HOOK-UP

1. Plug the oscillator board into the 14 pin connector on the back side of the display board.
2. Carefully plug in the power cable insuring that **Positive is at the corner.**
3. Plug in the RF coax cable
4. Plug the ribbon cable into J1 connector as shown below and the other end into the back side of the pushbutton board, oriented as shown.
6. This completes the connections. When power is applied the display should read 7000000 and there should be a 7MHz sine wave at the coax cable.

Front Side View

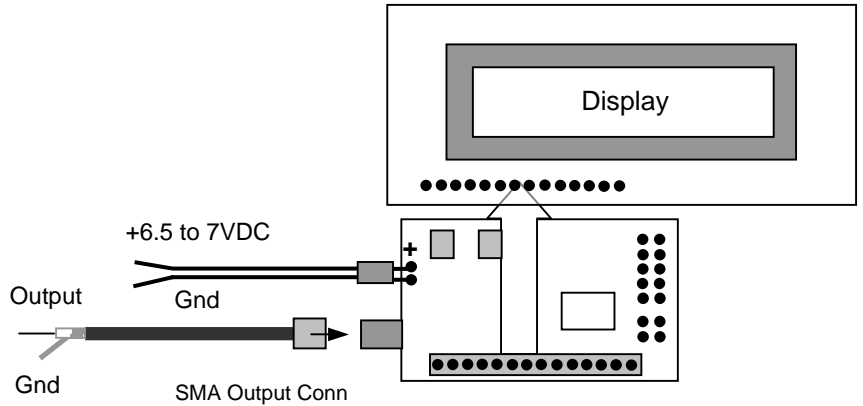

Output 1 10 1
Output 2

Back Side View

Pushbutton board –
PB1 = Band
PB2 = Fast Step

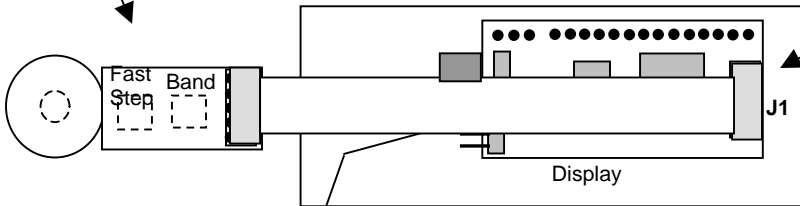

Note that there are two vias here marked G and O. This is an addition location for RF output – a small coax cable can be soldered here in case no SMA cable is available.

Connector J1 Pinout (Board view)

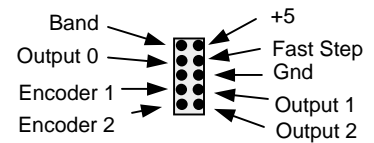

Connector J1 Pinout (Board view) for programming. Note this is the standard 6-pin AVR program interface.

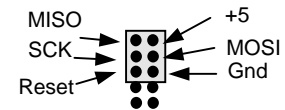

Gnd Line0 Line1 Line2

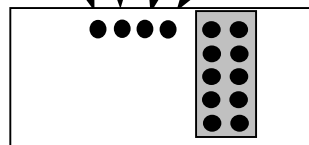

Bottom view of pushbutton board.
- 10-pin cable pinout is same as J1 on mainboard.
- Gnd and lines 0 – 2 are outputs for filters.

Rotary Encoder – types tested

1. DigiKey CT3001, CTS 288T232R161A1 (currently what comes with the unit)
2. DigiKey P12334, Panasonic
3. DigiKey P10859, Panasonic

DDSV4 Bill Of Material

U1 – Microcontroller, Atmel ATMEGA16, TQFP, (Digi-Key ATMEGA16-16AU-ND)
U2 – DDS, 400MHz, Analog Devices AD9859 (DK AD9859YSVZ-ND)
U3 – 25MHz Oscillator (DK 300-7216-1-ND)
U4 – 5V Adjustable Linear Regulator, SOIC-8 Micrel MIC39102 DK 576-1175-ND
U5 - 3.3V Linear Regulator, SOIC-8 Micrel MIC39101-3.3
U6 - 1.8V Adjustable Linear Regulator, SOT-23-5 TI TPS73201DBVR
U7 – MiniCircuits MAR-4
Display – 2 Lines X 16 Characters, Hantronix HDM16216L-B
FL1 – Low Pass Filter, Fco(10dB)=50MHz Panasonic ELK-TT560BA (DK P11100CT-ND)
Rotary Encoder CTS 288T232R161A1 (DK CT3001-ND)
J1– Header, 2X 5, .100" c-c, straight
J3 – Header, 1 X 16, .100" c-c, straight
Resistors and Caps are all 0603, SMD type as shown on the schematic

Spur Discussion

On an oscilloscope, the fundamental DDS output appears as a clean sine wave. However in any DDS design there will be some other frequency by-products. There are a number of reasons that these can occur such as DDS system clock feed-through, clock oscillator feed-through, and images of the output freq and the system freq. (Nyquist sampling theorem). Considerable effort was made to reduce all of these. In most applications the output spurs will be sufficiently low, however if a cleaner output is desired, then an additional low pass (high cut) filter can be added. The MAR-4 output is 50 Ohms impedance so any of the 50 Ohm filter designs will work.

Spur Measurements (Advantest 3GHz Spectrum Analyzer, with 50Ohm load at DDS output).

Freq	Close Spur	Spur Level	Note
3.5MHz	7MHz	-45dB	
7 MHz	14MHz	-45dB	
14MHz	28MHz	-45dB	
28MHz	56MHz,	-50dB	
50MHz	100MHz	-50dB	

Software features

To get into the user selectable features, hold down the left “Band” AND right “FastStep” buttons for one second anytime the unit is powered. When you see “Main Setup Menu” you have entered setup mode – quickly release the buttons. The display will now slowly cycle through the following – Step Size Select, Mode Select, Offset Freq Select and back again. When the option you want to access is being displayed, push the left button again. Push the right button to exit setup menu and go back to normal operation.

Step Size Select – the display will indicate “Sel. Step Size” and the current step size. Rotate the encoder to change step size to desired value. NOTE – this is the only mode where the value will not be saved when you turn off the unit. Push the right side button to go back to previous menu.

Mode Select – the display will now cycle through **Ham**, **SWL**, **SigGen** and **Audio Osc**. Push the left side button to select. The display will indicate that the mode was selected and go back to the original cycle. You can go on to other selections from there.

- In Ham mode the band step button are set for 1.8----50.0 MHz, with step size 100Hz and fast step of 3kHz
- In SWL mode the band step buttons are set for 1.8---28MHz, with step size 1kHz, and fast step 5kHz.
- In SigGen mode the band step buttons are set for 1.0 – 20 MHz, with step size 500Hz, fast step 10kHz.
- In Audio oscillator mode the step buttons are set for 880 Hz – 6kHz, with step size of 100 Hz.

Offset Select – the display indicates “Sel Offset Freq” and the current offset frequency. Push the Band button and/or rotate the encoder to select the offset frequency. As you push the button you will notice that the display will eventually cycle through negative numbers. These are to set up low side injection. For example an offset of 455000 means that the output frequency will be 455kHz above the displayed frequency. An offset of -455000 means that the output frequency will be 455kHz below the displayed frequency. Push the right side button to return to setup mode, push twice to go back to normal operation.

Display Options

The display interface is configured for the supplied Hantronix display which includes a backlight. You can use other displays, however attention needs to be paid to the pinout as some are slightly different.

The pinout is as shown below. As noted above the Hantronix display plugs directly on the header

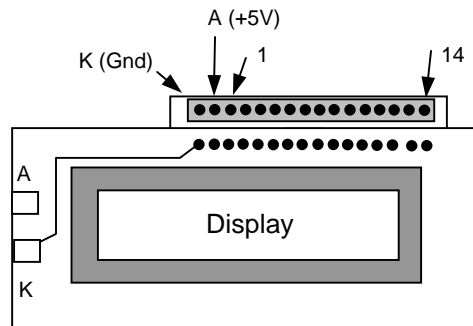

Using a Lumex display. The Lumex display has the backlight connector at the opposite end of the row and will need to be plugged in as follows. Notice that it has to be moved to the right two pins. In this case you can see that separate wires will need to be run to connect +5V and Gnd from the DDS board to the display.

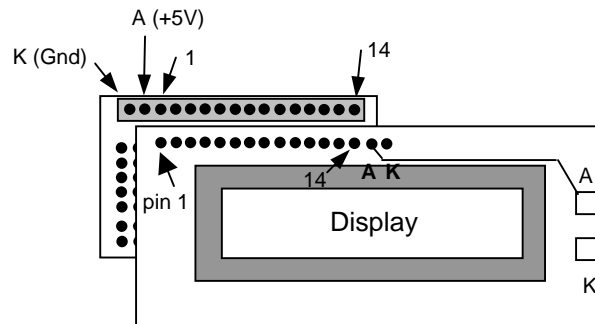

Cable Orientation

I have found the examples below useful.

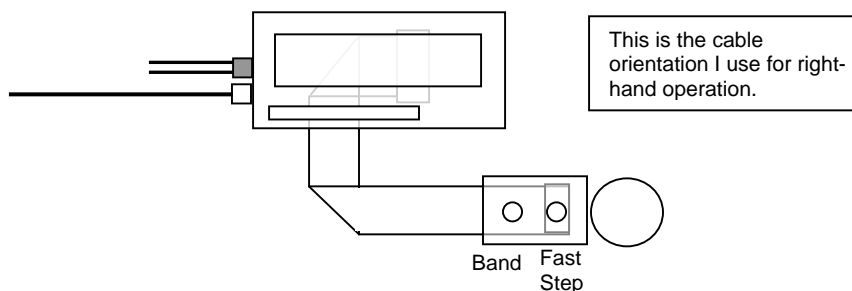

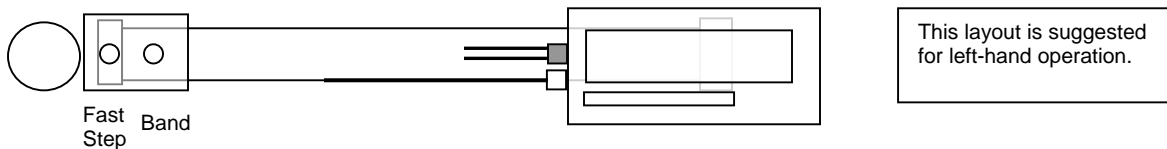

Output Amplitude

The DDSv4 is designed to provide enough output to drive a passive mixer – 800mV minimum. No control for is provided at this time as I figured this amount or higher would be desired in any case. Amplitude can be reduced easily with in-line resistors if necessary. DDS oscillators drop off in amplitude at higher frequencies, so the exception to the above design goal is at 50MHz. The highest I can coax out of it is 400mV at this time.

Operation at audio frequencies.

I have provided capability to use this as an audio oscillator, however the final amplifier configuration is designed for RF and severely attenuates audio frequencies. For operation at this range I suggest soldering a small wire to one of the two small vias just below the AD9859 DDS chip.

Source Code

I will be glad to provide source code. The code is written in BASIC and is easy to follow. I use the BASCOM BASIC compiler to generate hex code which I then load into the micro through the standard 6-pin avl ISP port. I highly recommend this compiler – it has many features which make code development much easier and faster.

Experimentation

I would encourage you to experiment with the DDSv4. Of course the original intention is that it be used as a local oscillator for a receiver, or as the frequency source for a transmitter. Some ideas are below.

1. Set up a new push-button arrangement.
2. Try higher quality encoders.
3. Build the unit into a small box with a battery and make a miniature portable signal generator.
4. For the really daring you can modify the source code to add new band stop frequencies, create a unit designed for a specific band, etc.

Maximum Output Frequency

The current maximum is only determined by the “Band” step settings. Since there wasn’t much of interest to most users in the 50 – 100 MHz range I didn’t program band stops in that range. However the core DDS frequency is running at 350MHz, so output to 100Mhz or even a bit higher should be no problem.

Custom Programming

I have done simple customization for some users in the past and can continue to do so. For a nominal fee – say \$20 I can set up a unit with custom band-stop frequencies or some other similar change. If interested contact me (Dick Tormet) at the e-mail address at the bottom of the page.

Outputs for RF Filters

The current implementation has three output lines to be used for receive (or output) filters. Note that I expanded the frequency range for each output setting to allow use of wider range receive filters for SWL use. This should not affect use for ham filters. The table below lists the output line status vs. frequency.

Ham Band (MHz)	SWL Band (MHz)	DDS Output Freq.	Line 3	Line 2	Line 1	Dec Val
	Broadcast (.54 – 1.7)	<1.8	0	0	0	0
160m (1.8–2.0)	120m (2.3 - 2.495)	>=1.8 to <2.8	0	0	1	1
80m (3.5–4.0)	90m (3.2 - 3.4) 75m (3.9 - 4.0) 60m (4.75 - 5.06) 49m (5.8 - 6.2)	>=2.8 to <6.2	0	1	0	2
40m (7.0 – 7.3)	41m (7.1 – 7.5)	>=6.2 to <9.5	0	1	1	3
30m (10.1 – 10.15)	31m (9.5 – 9.905) 25m (11.65 – 12.05)	>=9.5 to <14.0	1	0	0	4
20m (14.0 – 14.35)	19m (15.1 – 15.6) 16m (17.55 – 17.9)	>=14.0 to <18.0	1	0	1	5
17m (18.068-18.168) 15m (21.0 – 21.45)	13m (21.45 – 21.85)	>=18.0 to <24.0	1	1	0	6
12m (24.89 – 24.99) 10m (28.0 – 29.7)	11m (25.6 – 26.1)	>=24.0	1	1	1	7

The outputs for RF filtering are provided on the pushbutton board. There are three lines and will need to be decoded to provide filter capabilities. The logic condition will be true anytime the output frequency is within the band shown above. Any of the 3-to-8 line decoder/demultiplexers such as SN74LV138 and CD74HCT237, etc. should work for this application. I worked up an example schematic below using the HCT 237 which I found easier to set up since the logic is non-inverted.

